

CHARACTERISTICS SUMMARY

Model	Panels	Panels joining	Mirror	Suspended ceiling	Profiles	Floor finish	Car entrances and lintel
M-01	Melamine	Decorative satin AISI 304 stainless steel profiles	1/2 on back wall	Folding black plastic-covered plate (skinplate) with opal white metacrylate	Satin AISI 304 stainless steel	Black rubber circles	Satin AISI 304 stainless steel
M-02	Melamine	Vertical slats and satin AISI 304 stainless steel between-slats	1/2 on back wall	Folding black plastic-covered plate (skinplate) with opal white metacrylate	Satin AISI 304 stainless steel	Black rubber circles	Satin AISI 304 stainless steel
M-03	Melamine	Horizontal slats and satin AISI 304 stainless steel between-slats	Vertical slat on back wall	Folding black plastic-covered plate (skinplate) with opal white metacrylate	Satin AISI 304 stainless steel	Anti slip black rubber	Satin AISI 304 stainless steel
M-04	Melamine	Smooth car walls	Option: 1/2 on back wall	Folding black plastic-covered plate (skinplate) with opal white metacrylate	Black plastic covered plate	Black rubber circles	Satin AISI 304 stainless steel
S-01	Plastic covered plate (Skinplate)	-----	1/2 on back wall	Folding black plastic-covered plate (skinplate) with opal white metacrylate	Black plastic covered plate	Black rubber circles	Satin AISI 304 stainless steel

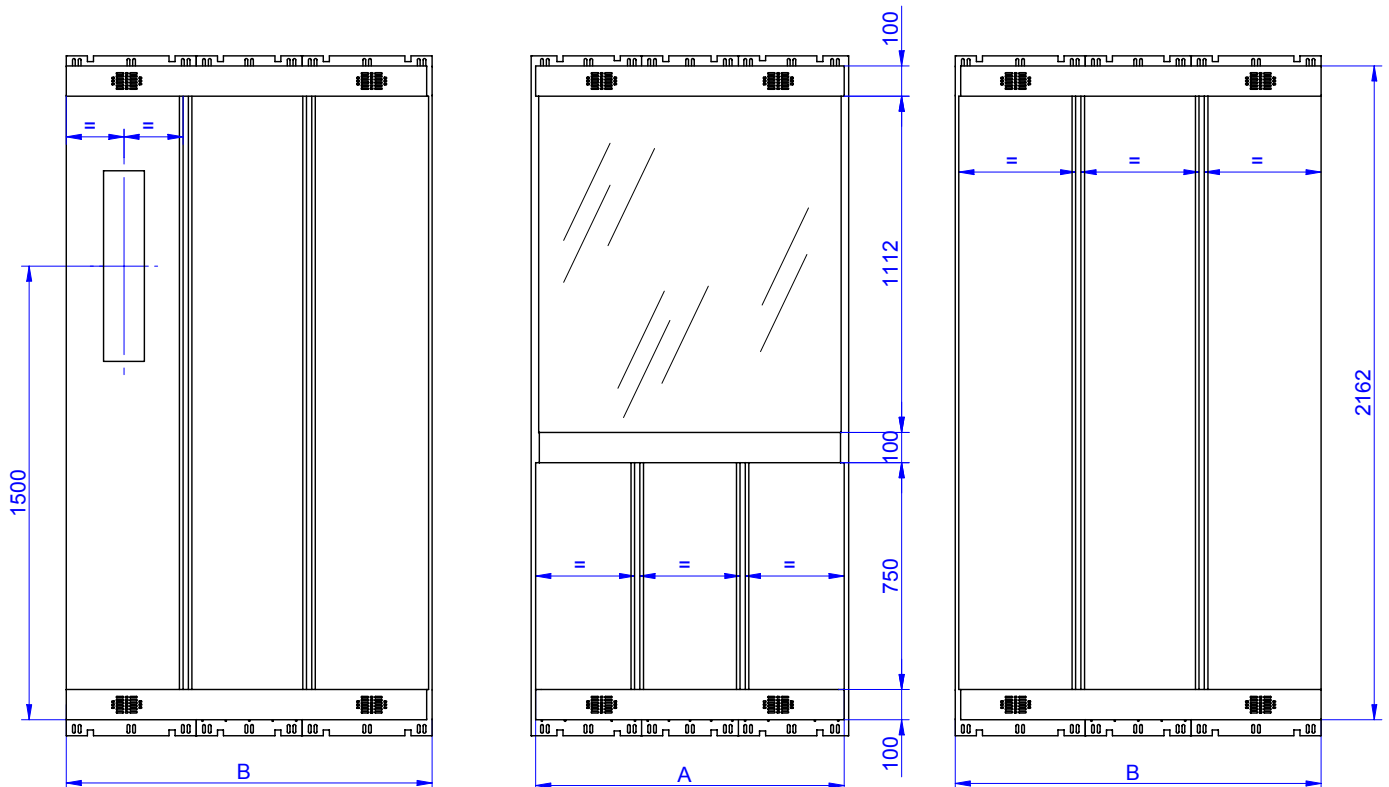

N° of panels depending on A or B
 B = Platform depth
 A = Platform width

STANDARD FEATURE

- * Number of landings: 1 or 2
- * Car walls galvanised plate lined with melamine with decorative satin AISI 304 stainless steel profiles.
- * 4 mm. safety mirror with polished edge, 1/2 height on back wall.
- * Folding black plastic-covered plate (skinplate) with opal-white metacrylate.
- * Satin AISI 304 stainless steel profiles (decorative profiles and upper lower skirtings).
- * Black rubber circles floor.
- * Car entrances and lintel satin AISI 304 stainless steel.
- * Plate car operating panel hole.

OPTIONS

- * Melamine, colors according to standard finishes.
- * Floor finish, according to standard finishes.
- * Suspended ceiling: according to catalogue.
- * Column car operating panel.
- * Aluminium or black plastic-covered plate (skinplate) profiles.
- * Handrails according to catalogue.

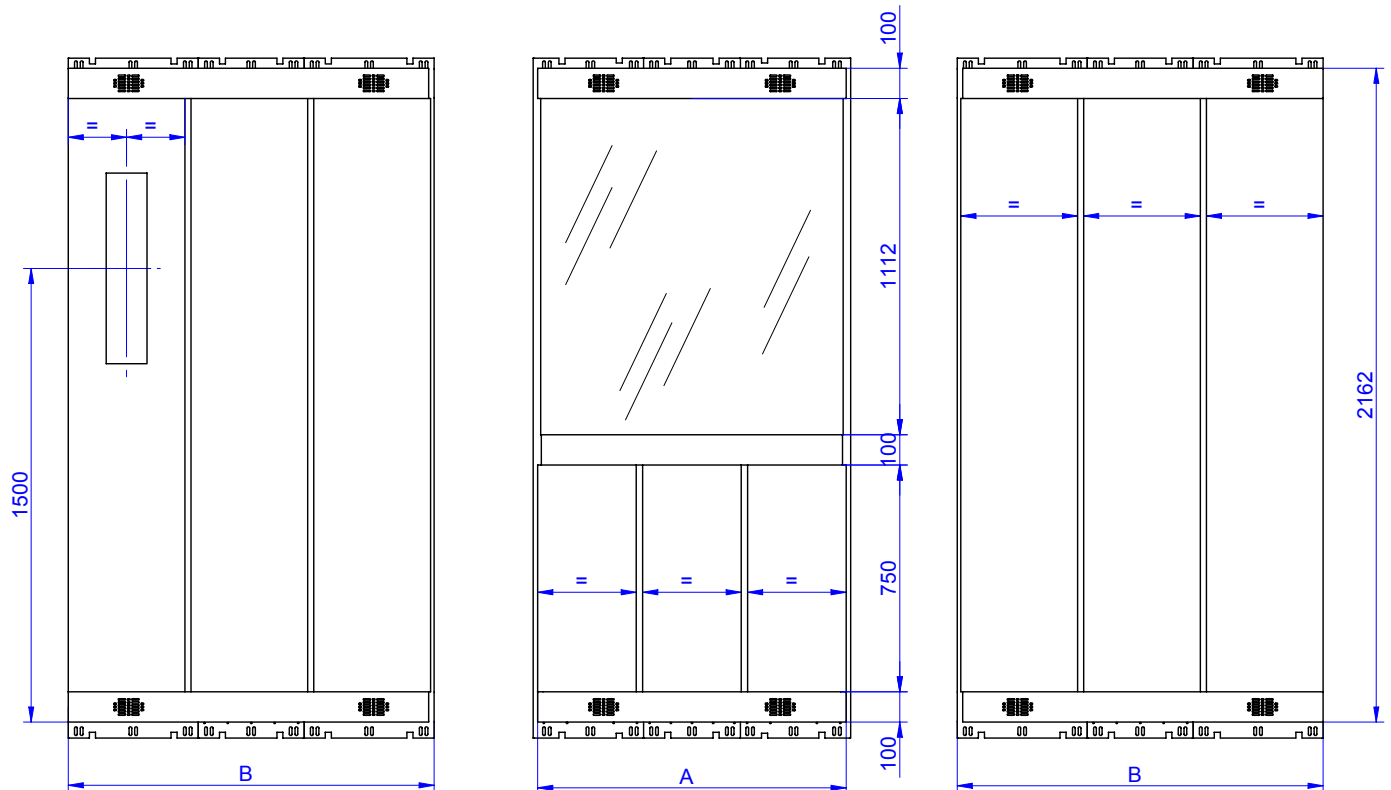

N° of panels depending on A or B
B = Platform depth
A = Platform width

STANDARD FEATURE

- * Number of landings: 1 or 2
- * Car walls galvanised plate lined with melamine, vertical slats and satin AISI 304 stainless steel between-slats.
- * 4 mm. safety mirror with polished edge, 1/2 height on back wall.
- * Folding black plastic-covered plate (skinplate) with opal-white metacrylate.
- * Satin AISI 304 stainless steel profiles (decorative profiles and upper and lower skirtings).
- * Black rubber circles floor.
- * Car entrances and lintel satin AISI 304 stainless steel.
- * Plate car operating panel hole.

OPTIONS

- * Melamine, colors according to standard finishes.
- * Floor finish, according to standard finishes.
- * Suspended ceiling: according to catalogue.
- * Column car operating panel.
- * Aluminium or black plastic covered plate (skinplate) profiles.
- * Handrails according to catalogue.

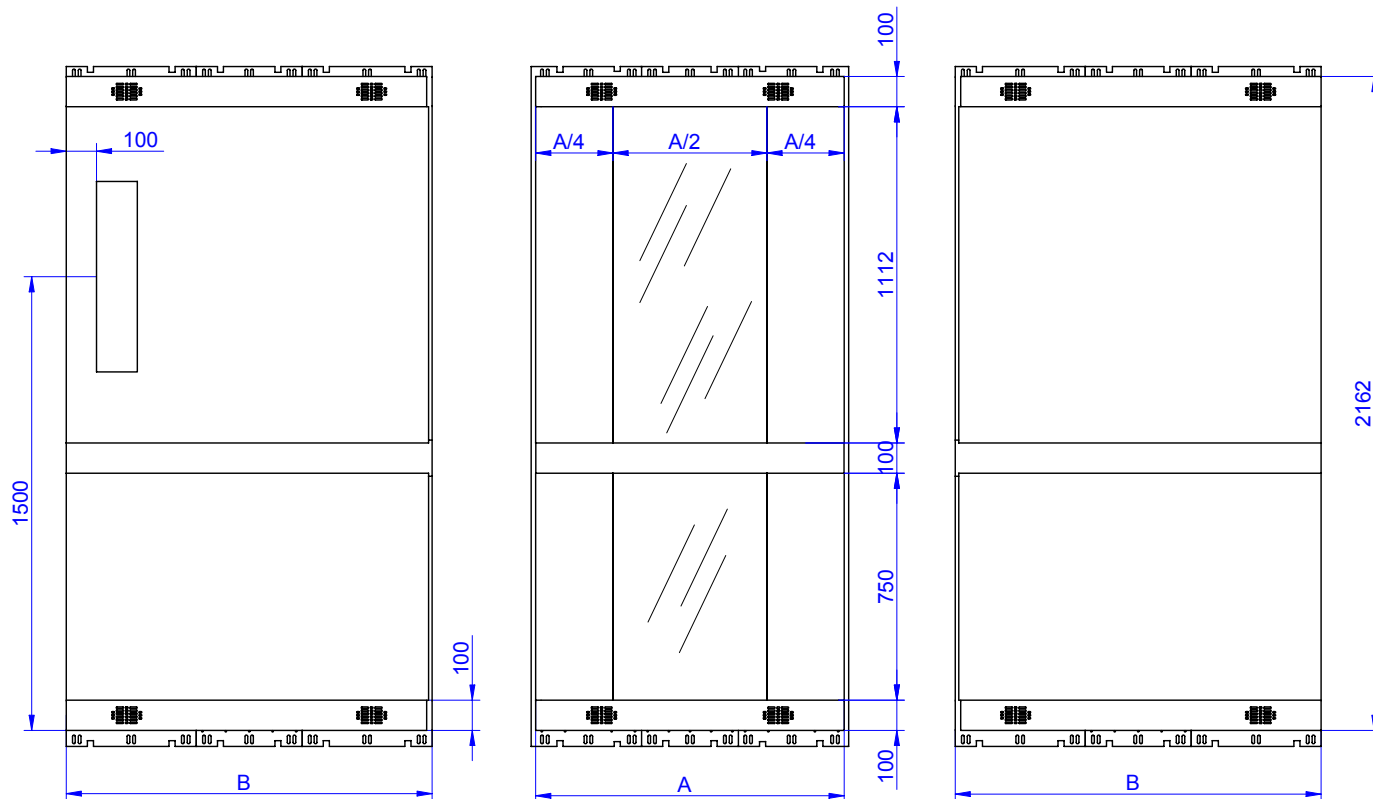

B = Platform depth
A = Platform width

STANDARD FEATURE

- * Number of landings: 1 or 2
- * Car walls galvanised plate lined with melamine, horizontal slats and satin AISI 304 stainless steel between-slats.
- * 4 mm. safety mirror with polished edge, vertical slat on back wall.
- * Folding black plastic-covered plate (skinplate) with opal-white metacrylate.
- * Satin AISI 304 stainless steel profiles (decorative profiles and upper and lower skirtings).
- * Anti-slip black rubber floor.
- * Car entrances and lintel satin AISI 304 stainless steel.
- * Plate car operating panel hole.

OPTIONS

- * Melamine, colors according to standard finishes.
- * Floor finish, according to standard finishes.
- * Suspended ceiling: according to catalogue.
- * Column car operating panel.
- * Aluminium or black plastic-covered plate (skinplate) profiles.
- * Handrails according to catalogue.

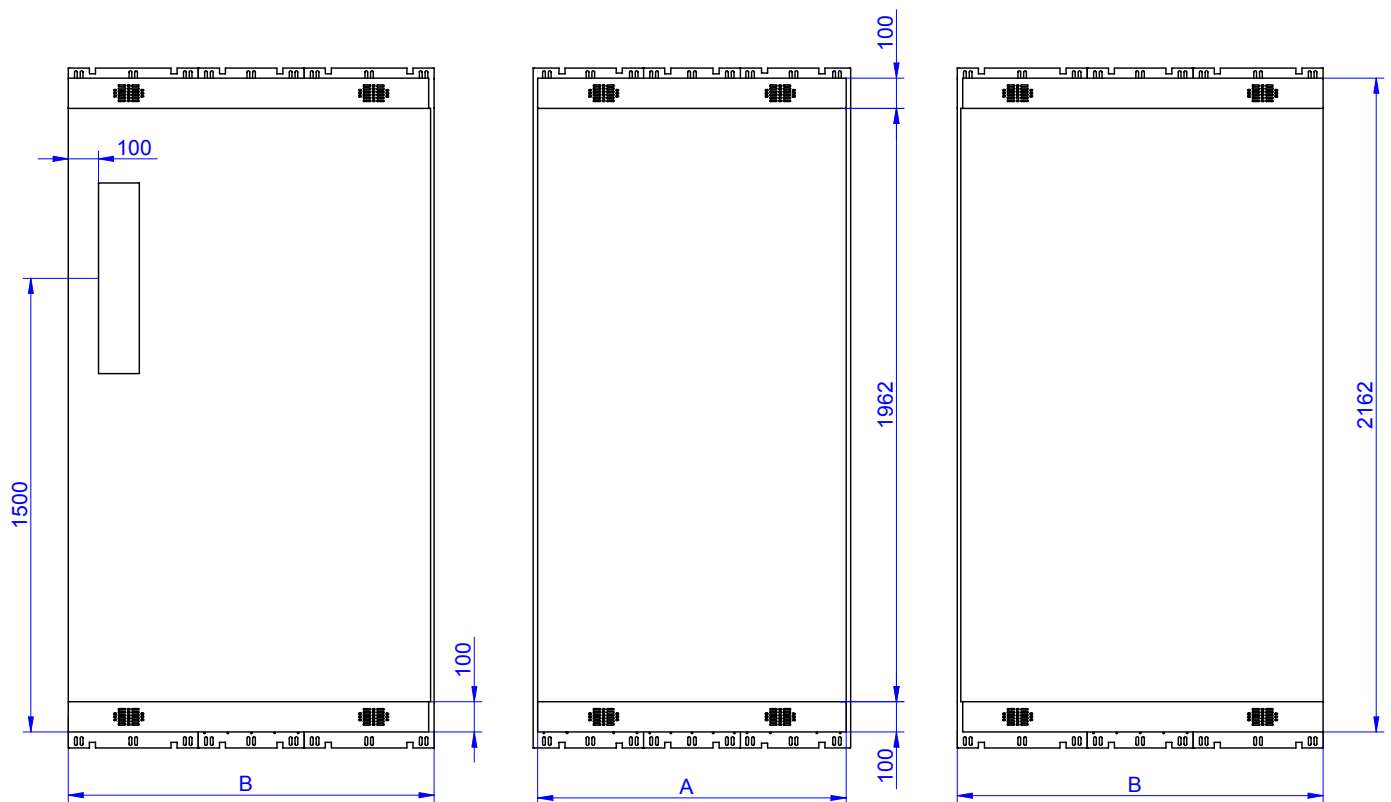

B = Platform depth
A = Platform width

STANDARD FEATURE

- * Number of landings: 1 or 2
- * Car walls galvanised plate lined with melamine, smooth car walls.
- * Folding black plastic covered plate (skinplate) with opal white metacrylate.
- * Black plastic-covered plate (skinplate) profiles (decorative profiles and upper and lower skirtings).
- * Black rubber circles floor.
- * Car entrances and lintel satin AISI 304 stainless steel.
- * Plate car operating panel hole.

OPTIONS

- * Melamine, colors according to standard finishes.
- * Floor finish, according to standard finishes.
- * Suspended ceiling: according to catalogue.
- * Column car operating panel.
- * Aluminium or satin AISI 304 stainless steel profiles.
- * Handrails according to catalogue.
- * 4 mm. safety mirror with polished edge, 1/2 height on back wall.

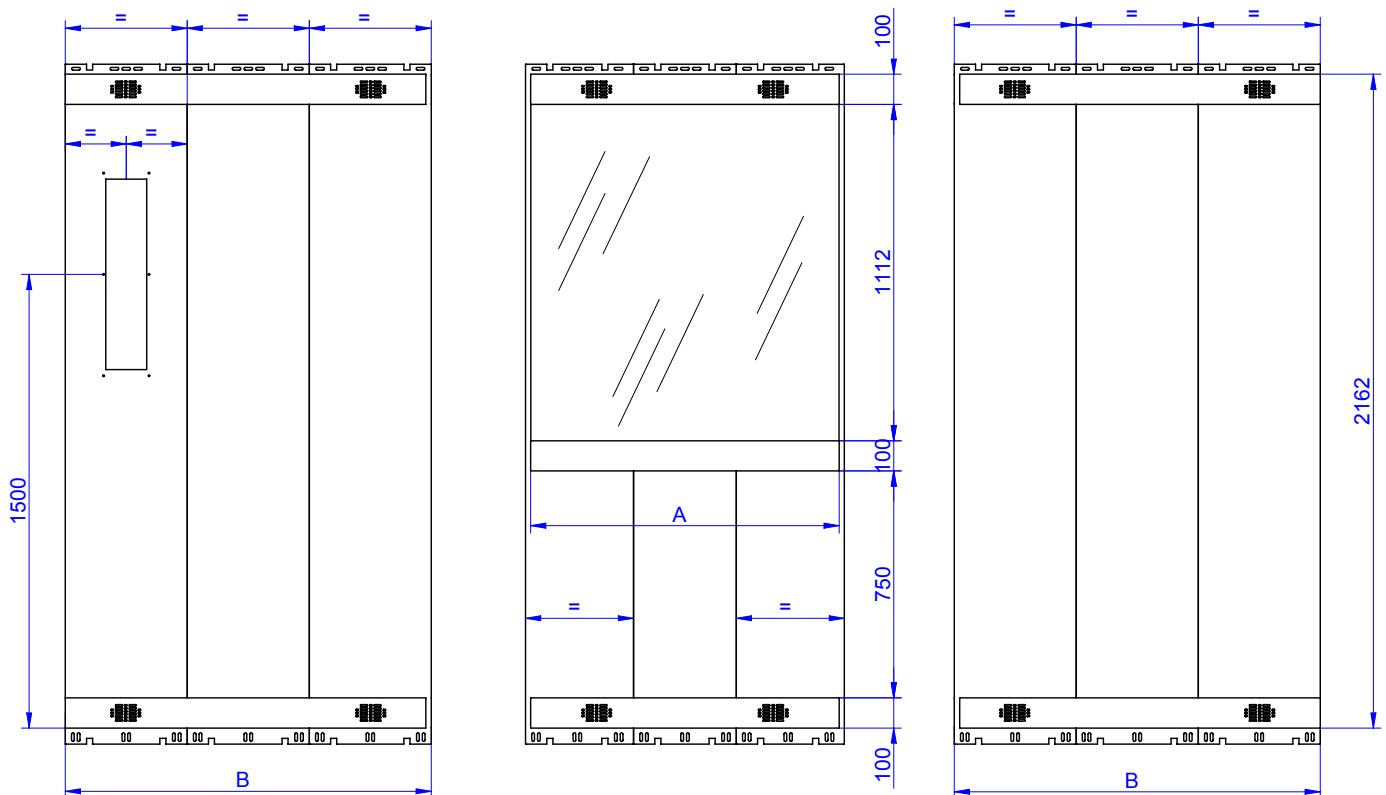

N° of panels depending on A or B
 B = Platform depth
 A = Platform width

STANDARD FEATURE

- * Number of landings: 1 or 2
- * Car walls plastic-covered plate (skinplate).
- * 4 mm. safety mirror with polished edge, 1/2 height on back wall.
- * Folding black plastic-covered plate (skinplate) with opal-white metacrylate
- * Black plastic-covered plate (skinplate) profiles (decorative profiles and upper and lower skirtings).
- * Black rubber circles floor.
- * Car entrances and lintel satin AISI 304 stainless steel.
- * Plate car operating panel hole.

OPTIONS

- * Plastic-covered plate (skinplate) panels, according to standard finishes.
- * Floor finish, according to standard finishes.
- * Suspended ceiling: according to catalogue.
- * Column car operating panel.
- * Aluminium or satin AISI 304 stainless steel profiles.
- * Handrails according to catalogue.

CHARACTERISTICS SUMMARY

Model	Panels	Panels joining	Mirror	Suspended ceiling	Profiles	Floor finish	Car entrances and lintel
L-01	Laminated	Decorative satin AISI 304 stainless steel profiles	½ on back wall	Folding black plastic-covered plate (skinplate) with opal white metacrylate	Satin AISI 304 stainless steel	Black rubber circles	Satin AISI 304 stainless steel
L-02	Laminated	Vertical slats and satin AISI 304 stainless steel between-slats	½ on back wall	Folding black plastic-covered plate (skinplate) with opal white metacrylate	Satin AISI 304 stainless steel	Black rubber circles	Satin AISI 304 stainless steel
L-03	Laminated	Horizontal slats and satin AISI 304 stainless steel between-slats	Vertical slat on back wall	Folding black plastic-covered plate (skinplate) with opal white metacrylate	Satin AISI 304 stainless steel	Anti slip black rubber	Satin AISI 304 stainless steel
L-04	Laminated	Smooth car walls	Option: ½ on back wall	Folding black plastic-covered plate (skinplate) with opal white metacrylate	Black plastic covered plate	Black rubber circles	Satin AISI 304 stainless steel
L-05	Laminated	Vertical slats and laminated between-slats	½ on back wall	Folding black plastic-covered plate (skinplate) with opal white metacrylate	Satin AISI 304 stainless steel	Anti slip black rubber	Satin AISI 304 stainless steel
I-01	Satin AISI 304 stainless steel	Vertical slats and satin AISI 304 stainless steel between-slats	½ on back wall and upper band	Folding black plastic-covered plate (skinplate) with opal white metacrylate	Satin AISI 304 stainless steel	Black rubber circles	Satin AISI 304 stainless steel

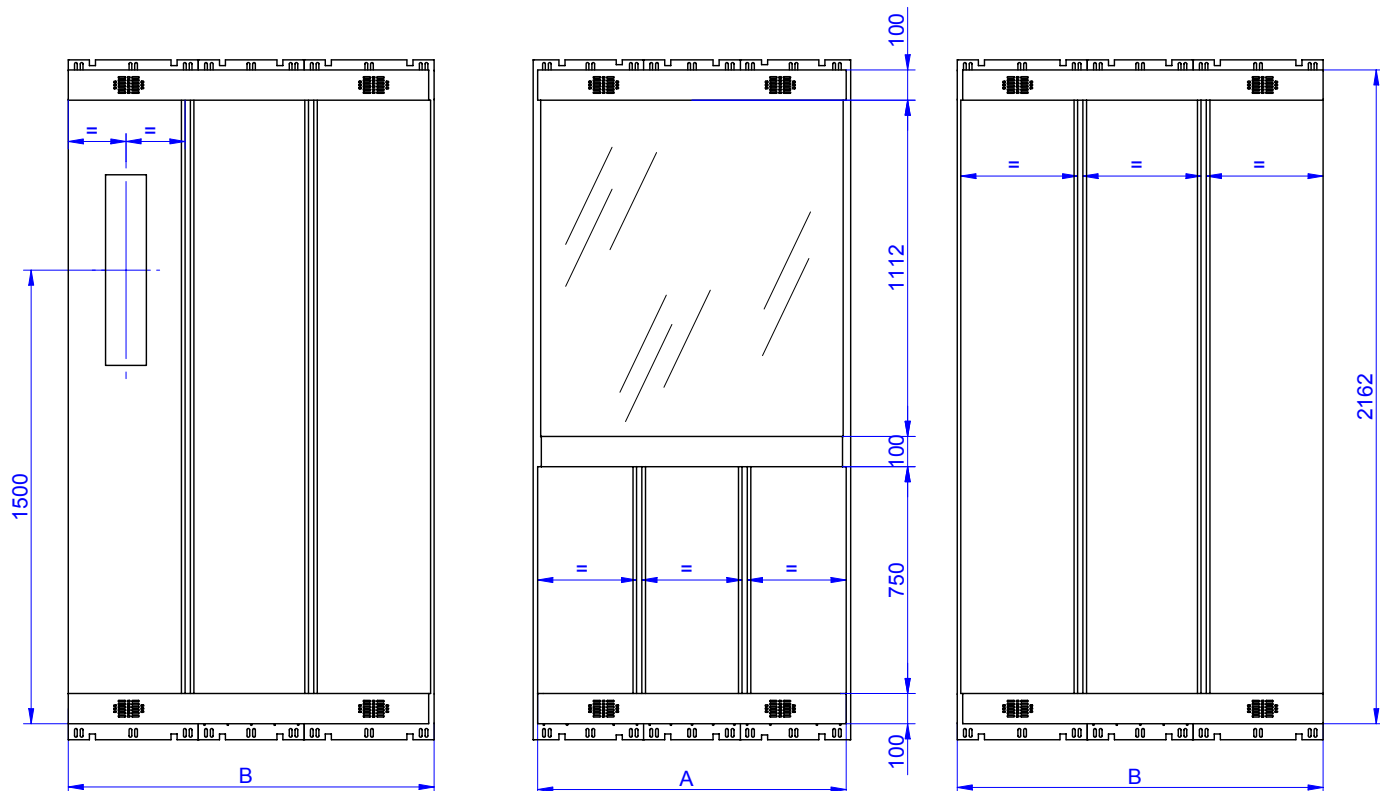

N° of panels depending on A or B
 B = Platform depth
 A = Platform width

STANDARD FEATURE

- * Number of landings: 1 or 2
- * Car walls galvanised plate lined with laminated with decorative satin AISI 304 stainless steel profiles.
- * 4 mm. safety mirror with polished edge, 1/2 height on back wall.
- * Folding black plastic-covered plate (skinplate) with opal-white metacrylate.
- * Satin AISI 304 stainless steel profiles (decorative profiles and upper lower skirtings).
- * Black rubber circles floor.
- * Car entrances and lintel satin AISI 304 stainless steel.
- * Plate car operating panel hole.

OPTIONS

- * Laminated, colors according to standard finishes.
- * Floor finish, according to standard finishes.
- * Suspended ceiling: according to catalogue.
- * Column car operating panel.
- * Aluminium or black plastic-covered plate (skinplate) profiles.
- * Handrails according to catalogue.

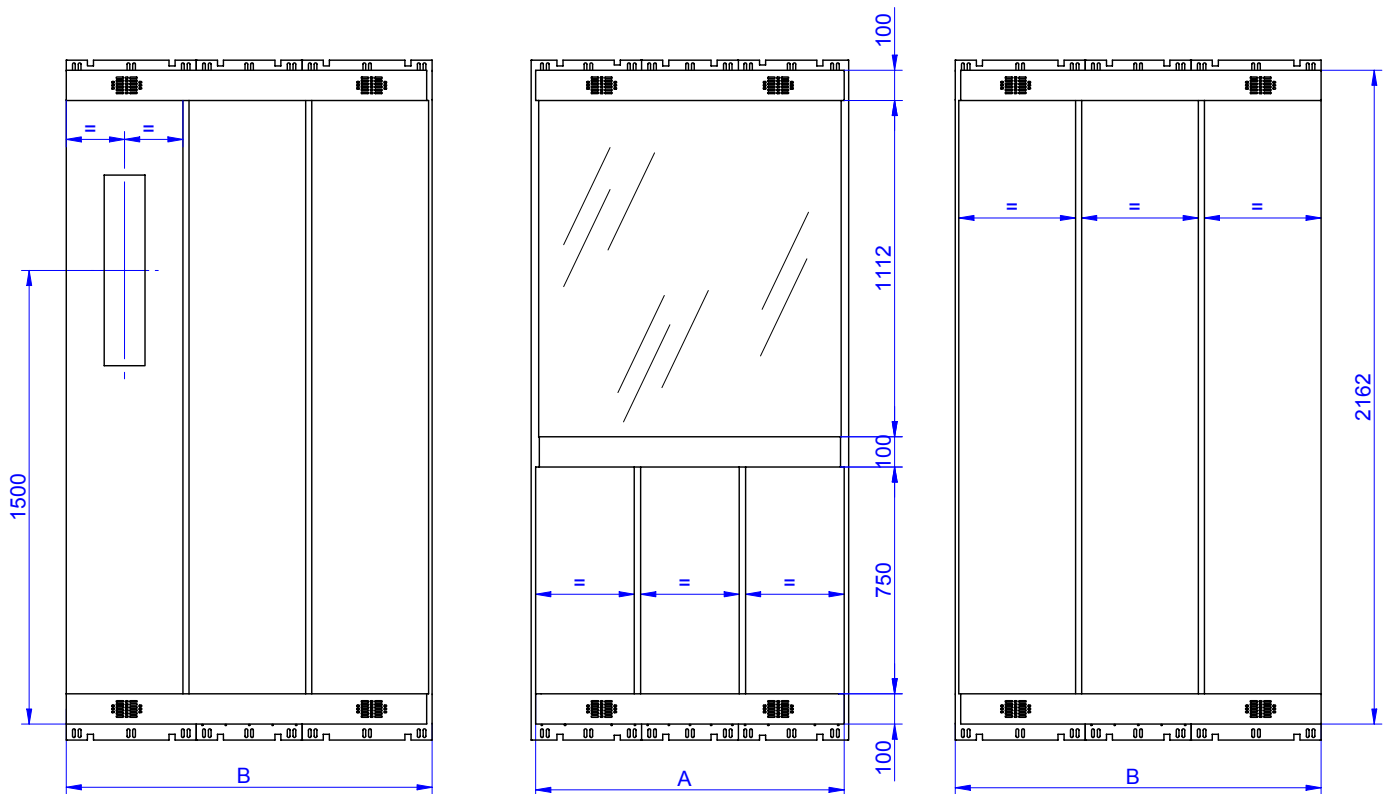

N° of panels depending on A or B
B = Platform depth
A = Platform width

STANDARD FEATURE

- * Number of landings: 1 or 2
- * Car walls galvanised plate lined with laminated, vertical slats and satin AISI 304 stainless steel between-slats.
- * 4 mm. safety mirror with polished edge, 1/2 height on back wall.
- * Folding black plastic-covered plate (skinplate) with opal-white metacrylate.
- * Satin AISI 304 stainless steel profiles (decorative profiles and upper and lower skirtings).
- * Black rubber circles floor.
- * Car entrances and lintel satin AISI 304 stainless steel.
- * Plate car operating panel hole.

OPTIONS

- * Laminated, colors according to standard finishes.
- * Floor finish, according to standard finishes.
- * Suspended ceiling: according to catalogue.
- * Column car operating panel.
- * Aluminium or black plastic covered plate (skinplate) profiles.
- * Handrails according to catalogue.

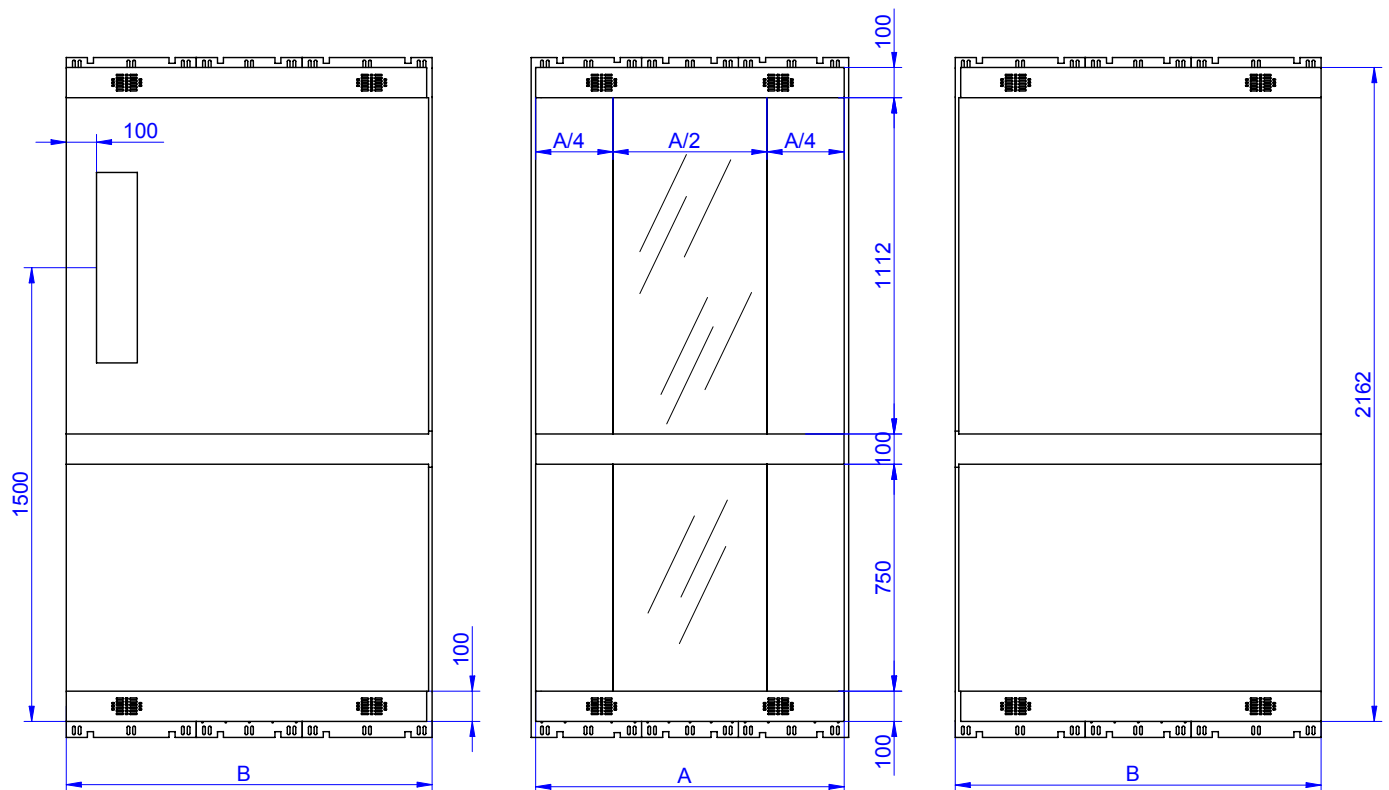

B = Platform depth
A = Platform width

STANDARD FEATURE

- * Number of landings: 1 or 2
- * Car walls galvanised plate lined with laminated, horizontal slats and satin AISI 304 stainless steel between-slats.
- * 4 mm. safety mirror with polished edge, vertical slat on back wall.
- * Folding black plastic-covered plate (skinplate) with opal-white metacrylate.
- * Satin AISI 304 stainless steel profiles (decorative profiles and upper and lower skirtings).
- * Anti-slip black rubber floor.
- * Car entrances and lintel satin AISI 304 stainless steel.
- * Plate car operating panel hole.

OPTIONS

- * Laminated, colors according to standard finishes.
- * Floor finish, according to standard finishes.
- * Suspended ceiling: according to catalogue.
- * Column car operating panel.
- * Aluminium or black plastic-covered plate (skinplate) profiles.
- * Handrails according to catalogue.

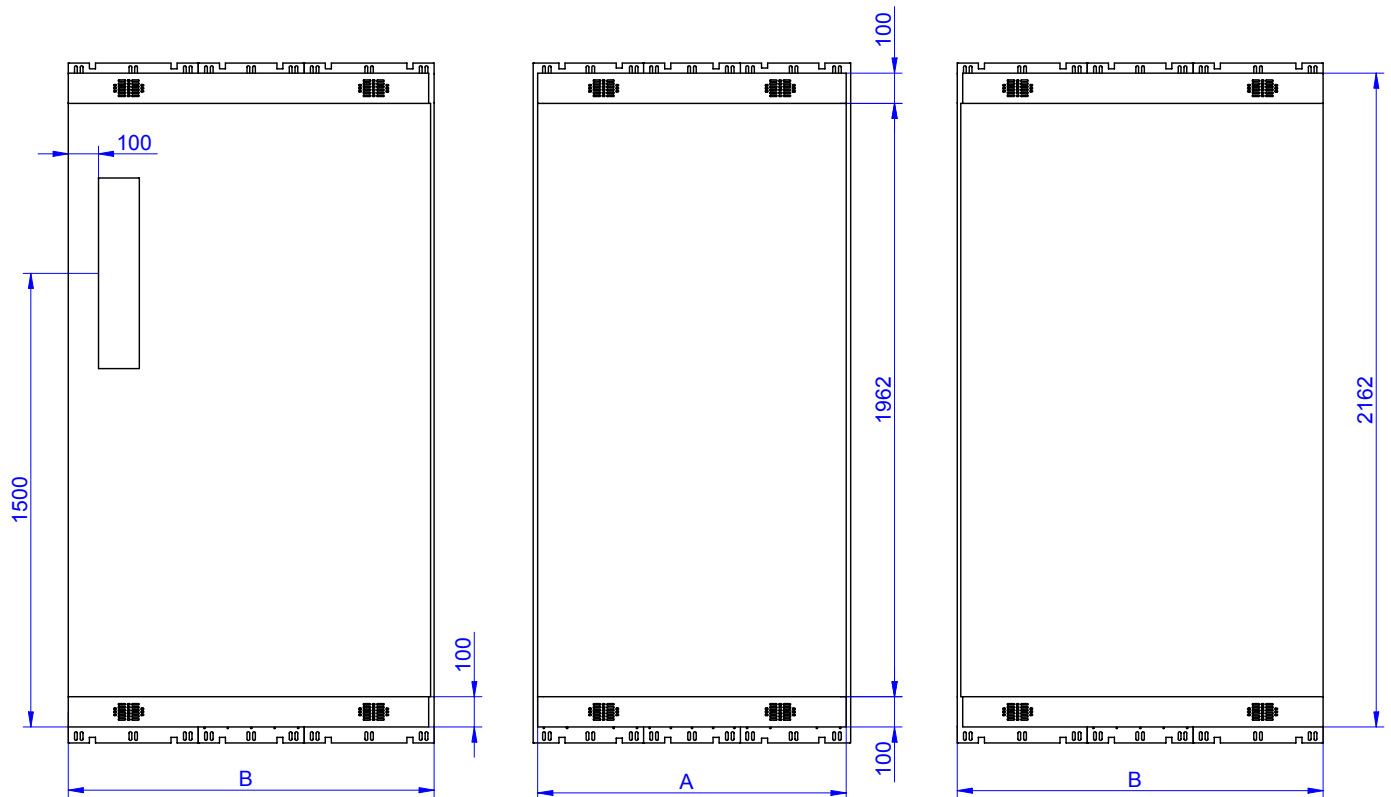

B = Platform depth
A = Platform width

STANDARD FEATURE

- * Number of landings: 1 or 2
- * Car walls galvanised plate lined with laminated, smooth car walls.
- * Folding black plastic covered plate (skinplate) with opal white metacrylate.
- * Black plastic-covered plate (skinplate) profiles (decorative profiles and upper and lower skirtings).
- * Black rubber circles floor.
- * Car entrances and lintel satin AISI 304 stainless steel.
- * Plate car operating panel hole.

OPTIONS

- * Laminated, colors according to standard finishes.
- * Floor finish, according to standard finishes.
- * Suspended ceiling: according to catalogue.
- * Column car operating panel.
- * Aluminium or satin AISI 304 stainless steel profiles.
- * Handrails according to catalogue.
- * 4 mm. safety mirror with polished edge, 1/2 height on back wall.

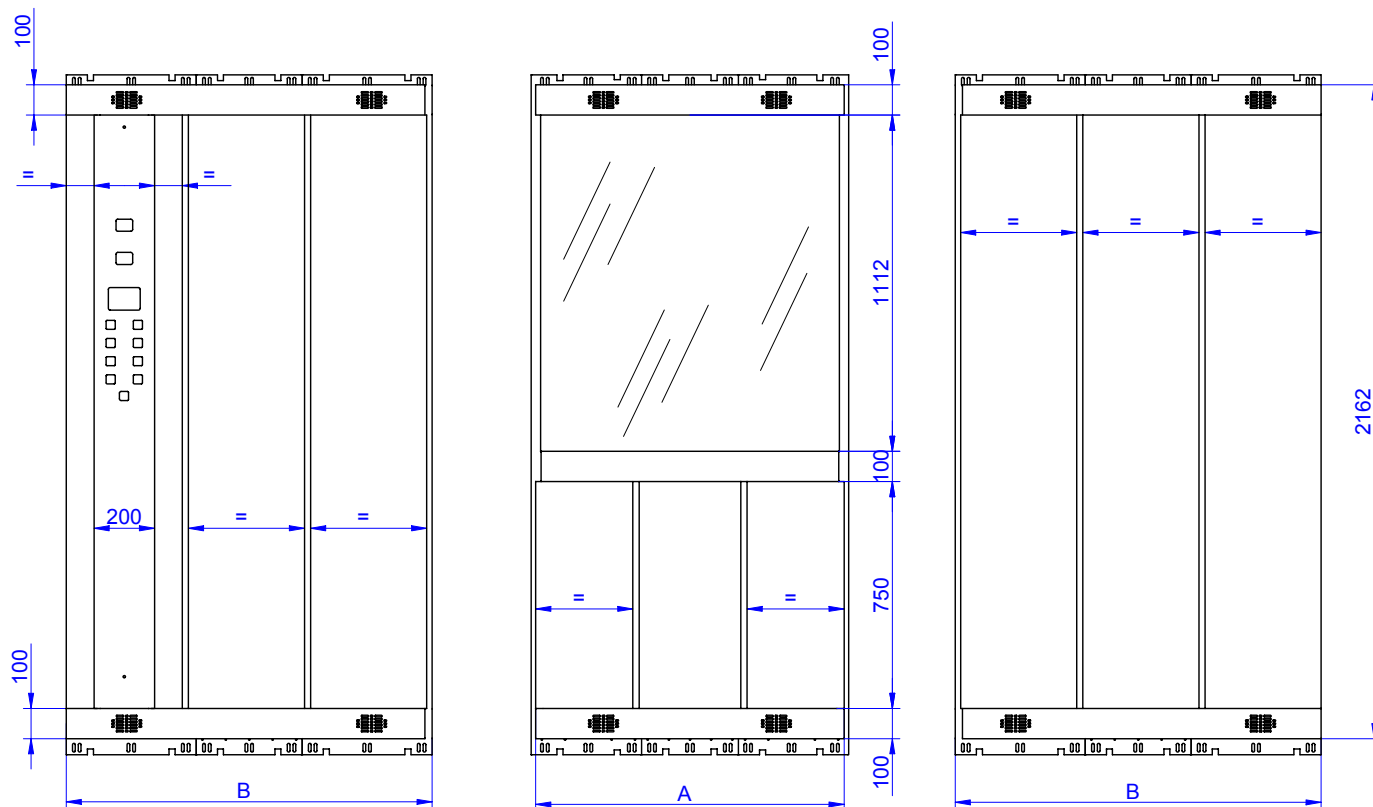

N° of panels depending on A or B
 B = Platform depth
 A = Platform width

STANDARD FEATURE

- * Number of landings: 1 or 2
- * Car walls galvanised plate lined with post-formed laminated with decorative laminated between slats.
- * 4 mm. safety mirror with polished edge, 1/2 height on back wall.
- * Folding black plastic-covered plate (skinplate) with opal-white metacrylate.
- * Satin AISI 304 stainless steel profiles (decorative profiles and upper and lower skirtings).
- * Anti-slip black rubber floor.
- * Satin AISI 304 stainless steel lintel and car entrances.
- * Column car operating panel.

OPTIONS

- * Laminate, colors according to standard finishes.
- * Floor finish, according to standard finishes.
- * Suspended ceiling: according to catalogue.
- * Aluminium or black plastic-covered plate (skinplate) profiles.
- * Handrails according to catalogue.

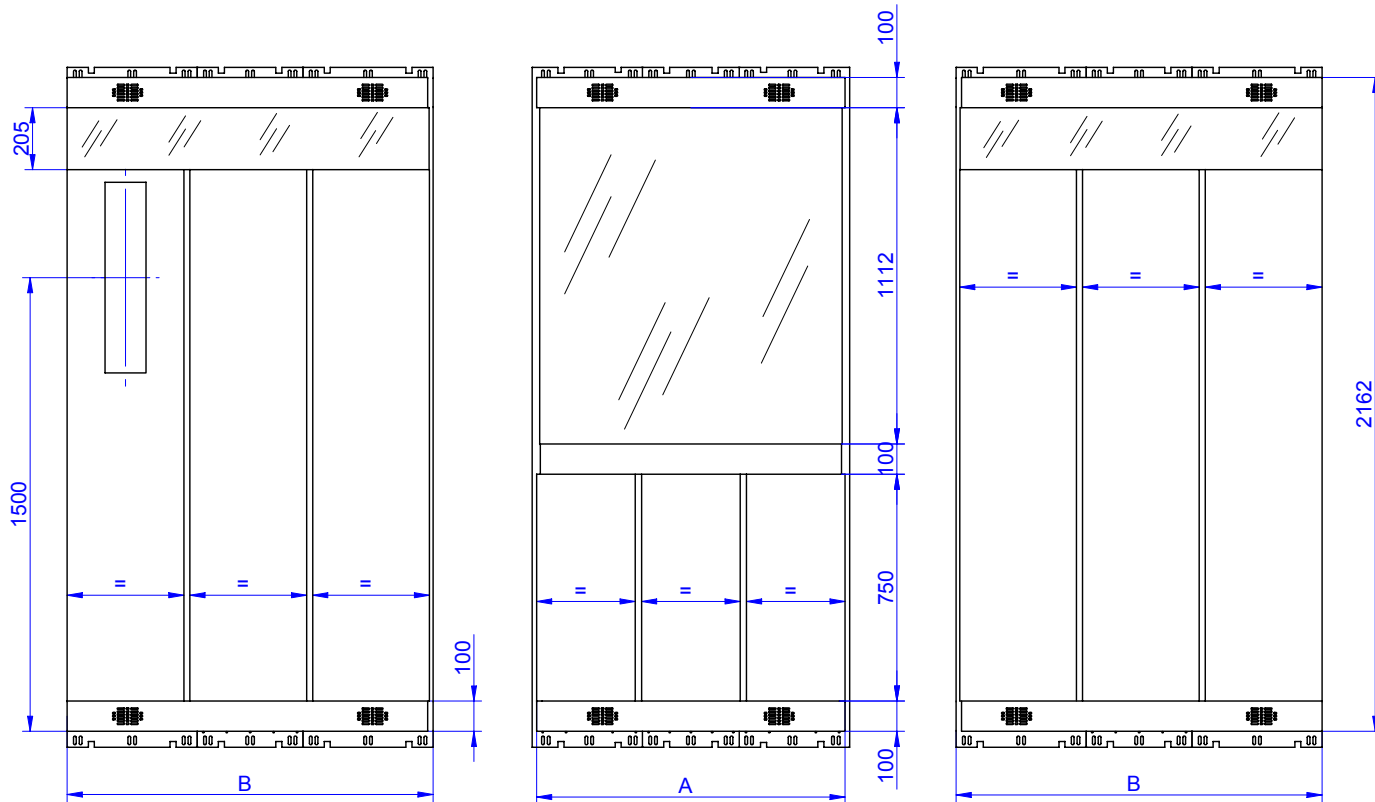

N° of panels depending on A or B
 B = Platform depth
 A = Platform width

STANDARD FEATURE

- * Number of landings: 1 or 2
- * Car walls galvanized plate lined with satin AISI 304 stainless steel, with satin AISI 304 stainless steel between-slats.
- * 4 mm. safety mirror with polished edge, upper band and 1/2 height on back wall.
- * Folding black plastic-covered plate (skinplate) with opal white metacrylate.
- * Satin AISI 304 stainless steel profiles (decorative profiles and upper and lower skirtings).
- * Black rubber circles floor.
- * Satin AISI 304 stainless steel lintel and car entrances.
- * Plate car operating panel hole.

OPTIONS

- * Floor finish, according to standard finishes.
- * Suspended ceiling: according to catalogue.
- * Column car operating panel.
- * Aluminium or black plastic-covered plate (skinplate) profiles.
- * Handrails according to catalogue.

CHARACTERISTICS SUMMARY

Model	Panels	Panels joining	Mirror	Suspended ceiling	Profiles	Floor finish	Car entrances and lintel
A-01	Laminated and stainless steel	Without joinings	Vertical slat on back wall	Laminated and stainless steel with halogen lights	Stainless steel	Granite	Satin AISI 304 stainless steel
A-02	Stainless steel	Without joinings	1/2 on back wall	Folding stainless steel with ice laminated glass 3+3	Stainless steel colored	Silestone	Satin AISI 304 stainless steel
A-03	Laminated	Without joinings	Full on back wall, diagonal on side walls	Stainless steel diagonal shape with ice laminated glass 3+3 and halogen lights	Stainless steel	Silestone	Satin AISI 304 stainless steel

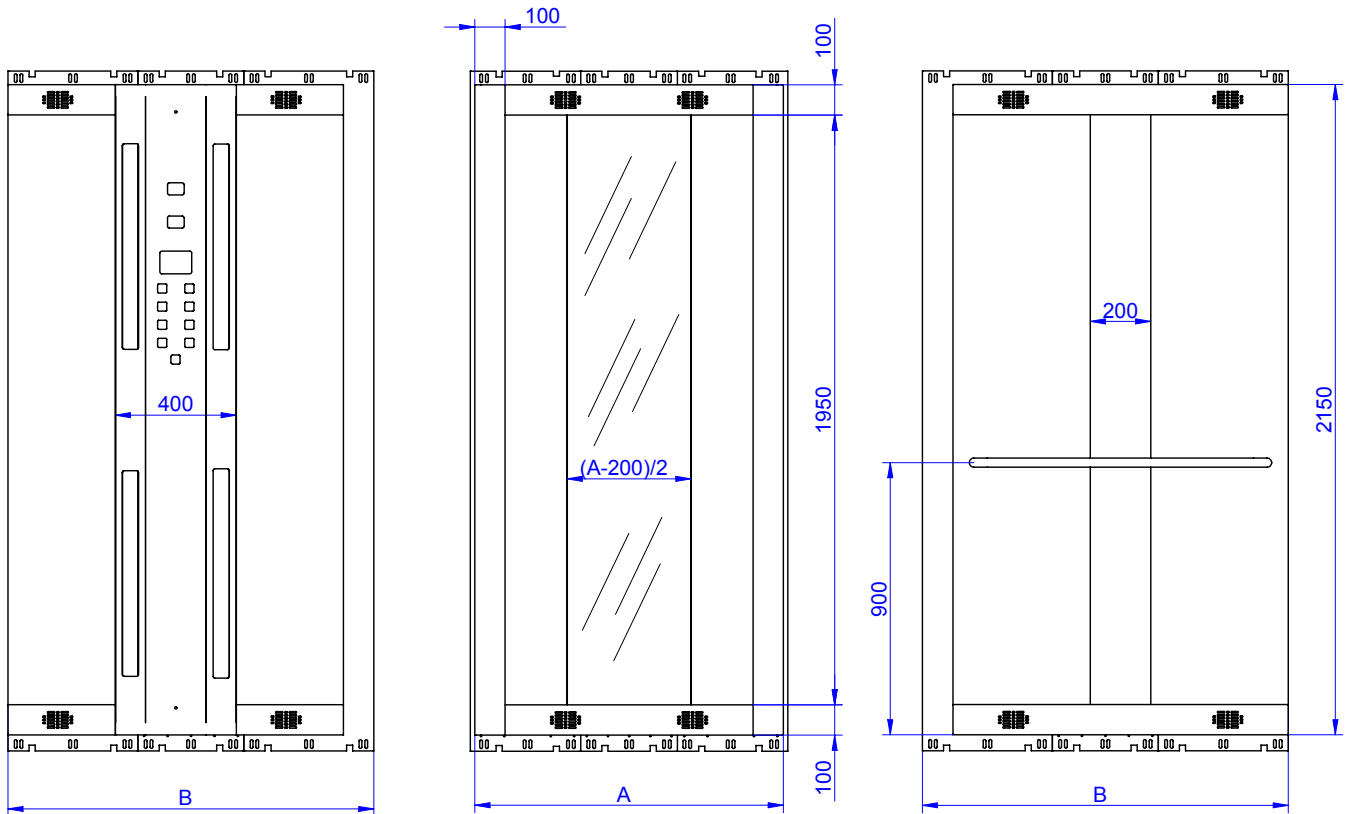

B = Platform depth
A = Platform width

Ceiling detail

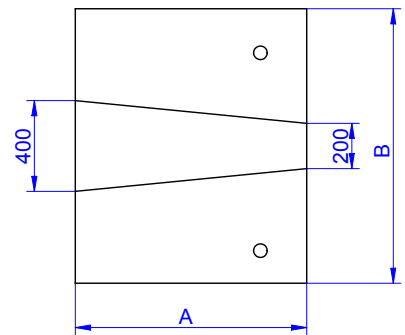

ESTANDARD FEATURE

- * Number of landings: 1 or 2
- * Car walls galvanised plate lined with laminated. AISI 304 stainless steel profile in front of column car operating panel. Stainless steel profiles on the back corners.
- * 4 mm. safety mirror with polished edge, vertical slat on back wall.
- * Ceiling: Laminated and stainless steel with halogen lights.
- * Satin AISI 304 stainless steel profiles (decorative profiles and upper lower skirtings).
- * Granite floor.
- * Car entrances and lintel satin AISI 304 stainless steel.
- * Column car operating panel with fluorescent lightning.
- * Handrails according to catalogue.

OPTIONS

- * Laminated and profiles, colors according to standard finishes.
- * Floor finish, according to standard finishes.

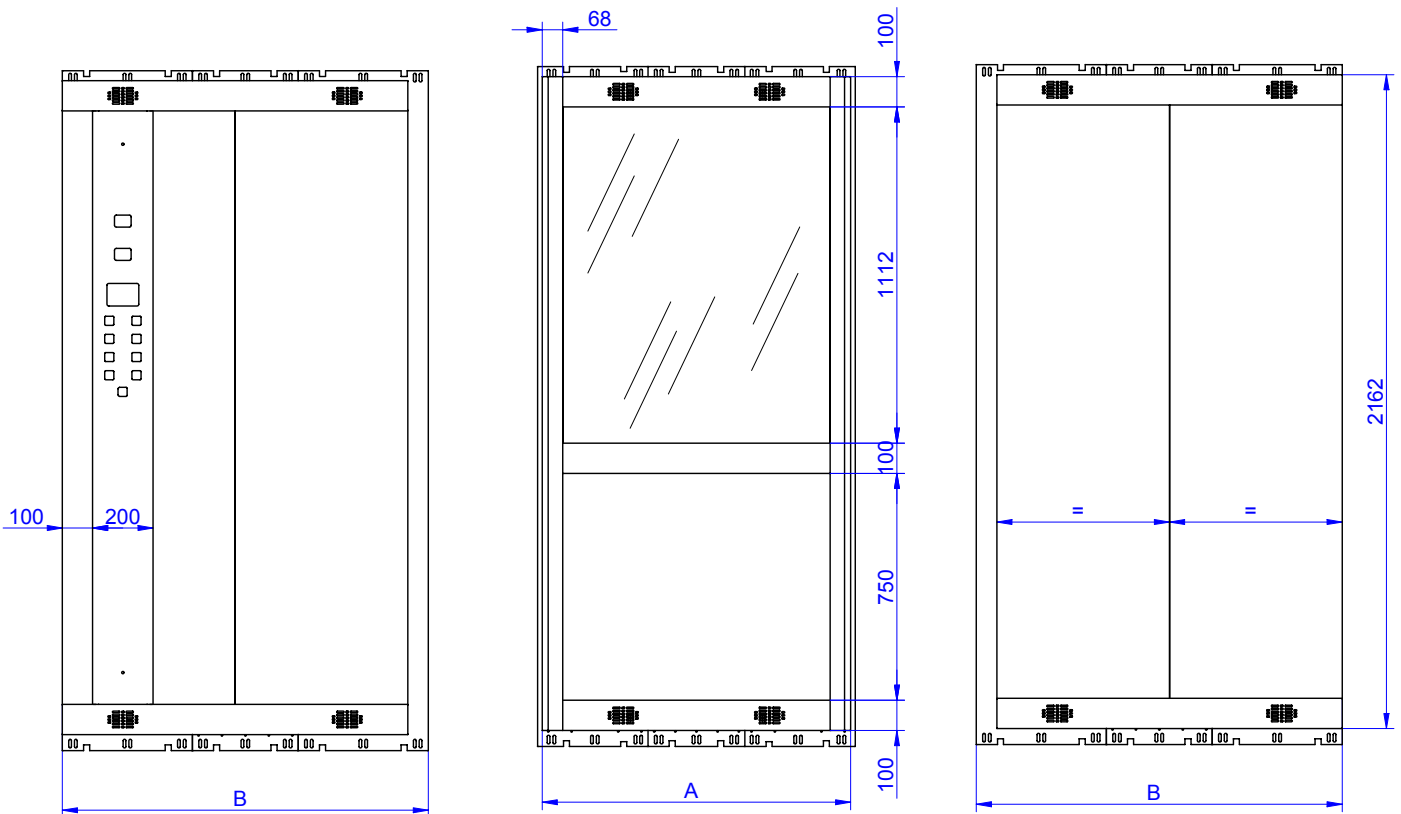

B = Platform depth
A = Platform width

STANDARD FEATURE

- * Number of landings: 1 or 2
- * Car walls galvanized plate lined with AISI 304 stainless steel. AISI 304 stainless steel profiles on the back corners.
- * 4 mm. safety mirror with polished edge, 1/2 height on back wall.
- * Folding suspended ceiling, AISI 304 stainless steel with ice laminated glass 3+3.
- * Colored AISI 304 stainless steel profiles (decorative profiles and upper and lower skirtings).
- * Silestone floor.
- * Satin AISI 304 stainless steel lintel and car entrance.
- * Colored AISI 304 stainless steel column car operating panel.

OPTIONS

- * AISI 304 stainless steel, according to catalogue.
- * Floor finish, according to standard finishes.
- * Suspended ceiling, according to catalogue.
- * Handrails according to catalogue.

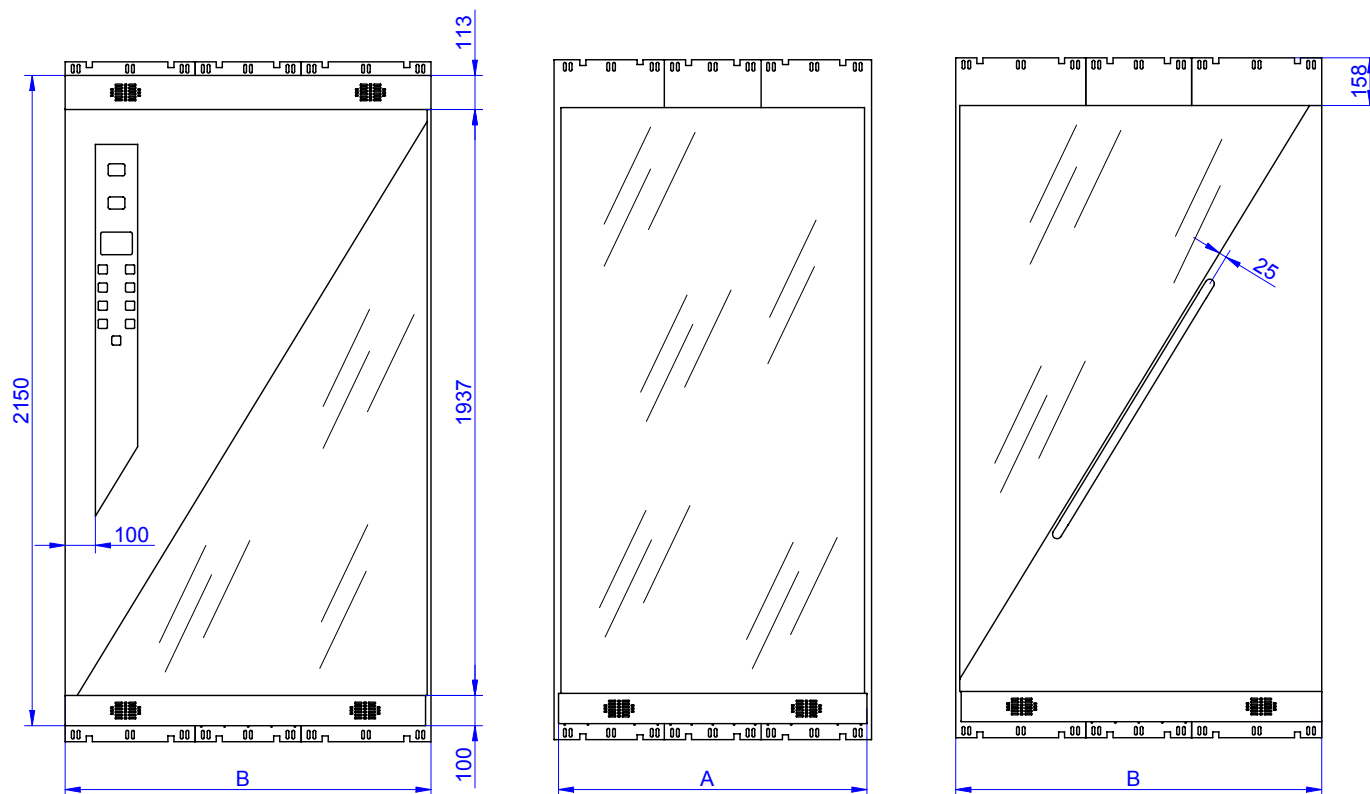

B = Platform depth
A = Platform width

STANDARD FEATURE

- * Number of landings: 1 or 2
- * Car walls galvanised plate lined with laminated.
- * 4 mm. safety mirror with polished edge, full on back wall, diagonal on side walls, white.
- * AISI 304 stainless steel diagonal shape with ice laminated glass 3+3 and halogen lights.
- * Satin AISI 304 stainless steel profiles (decorative profiles and upper and lower skirtings).
- * Silestone floor.
- * Satin AISI 304 stainless steel lintel and car entrances.
- * Satin AISI 304 stainless steel plate car operating panel.
- * Diagonal round handrail.

OPTIONS

- * Laminated, colors according to standard finishes.
- * Floor finish, according to standard finishes.

TYPE 1

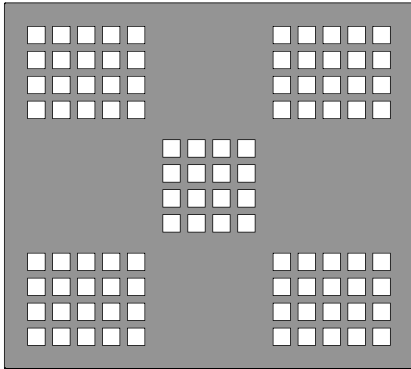

TYPE 2

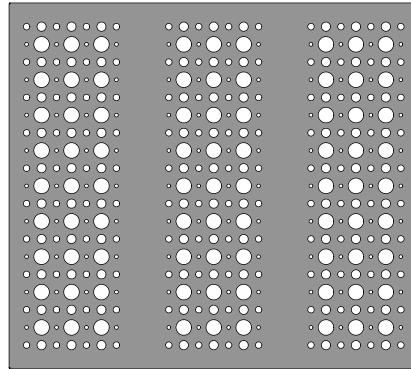

TYPE 3

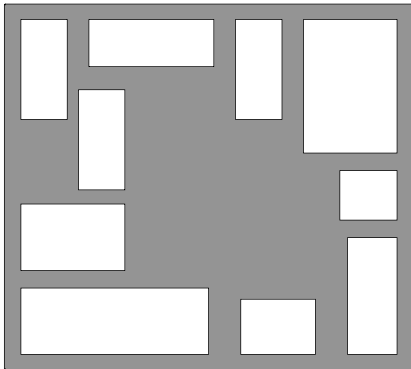

TYPE 4

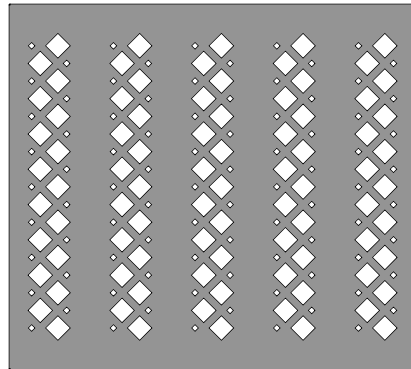

TYPE 5

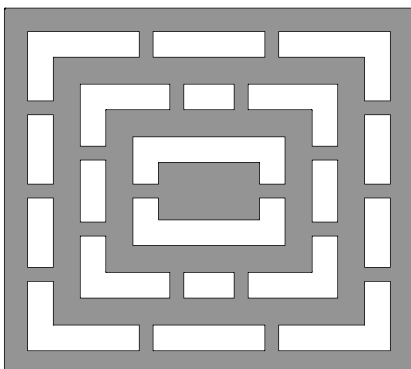

TYPE 6

